

Rother Sicherheitszentrale

Hilpoltsteiner Straße 59
91154 Roth

Tel: 09171 / 63900

info@rother-sicherheitszentrale.de

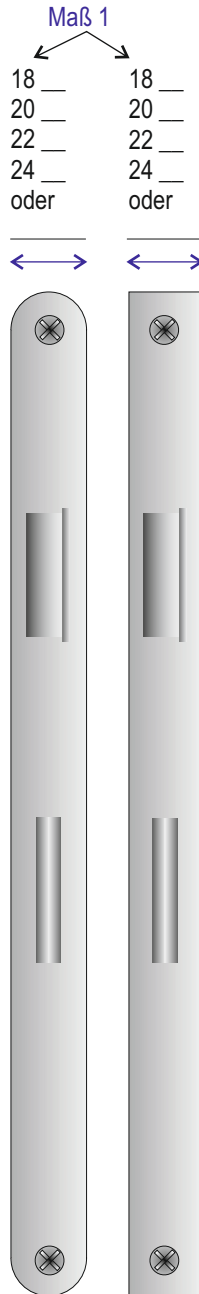

Kundenname _____

Türebezeichnung _____

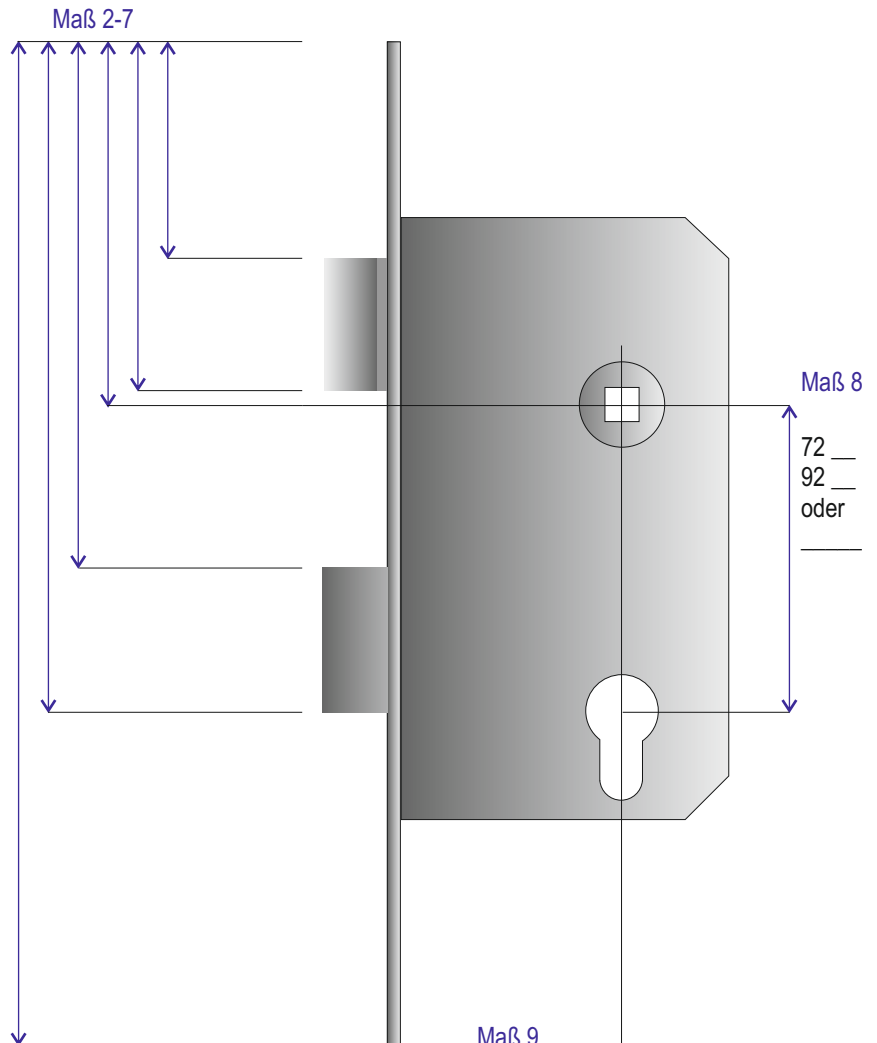

In welche Richtung öffnet sich Ihre Türe? Bitte ankreuzen!

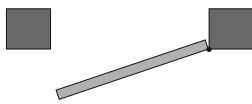

Din Rechts

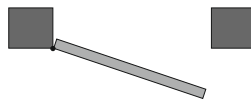

Din Links